

# Rigitone® Edge Activ'Air®



## Design and Technique

### Product description

Rigitone Edge is a gypsum based acoustic ceiling with high design value since no joints are visible. The ceiling can be used for many applications like schools, offices and commercial settings. Rigitone Edge is a 12,5mm thick gypsum board. It is screw mounted and therefore non-demountable. The board has on its backside a light grey acoustic tissue.

### Construction height

A minimum height of 185 mm is needed (Standard GK system in 2 levels, with hangers). If in need of a lower construction height, please contact Gyproc.

### Surfaces

The plasterboard surface is subject to paint treatment after installation. Treatment is to be executed with a roller as spray painting will impair the acoustic performance. Joints are to be filled, sanded and painted.

### Board type / Modular size

- |                               |              |
|-------------------------------|--------------|
| • Rigitone Edge 8/18          | 1188x1998 mm |
| • Rigitone Edge 12-20/66      | 1188x1980 mm |
| • Rigitone Edge 8-15-20       | 1109x2000 mm |
| • Rigitone Edge 8-15-20 Super | 1204x1960 mm |
| • Rigitone Edge 8/18Q         | 1188x1998 mm |
| • Rigitone Edge 12/25Q        | 1200x2000 mm |

### Tolerances / Actual size

Tolerance on the Rigitone board is:

- Length: +1 / -1 mm
- Width: +1 / -1 mm

### Weight

Approx. 8-10 kg/m<sup>2</sup> depending of the perforations type.

### Grid system

Rigitone Edge is to be installed on metal framing, GK system in 2 levels. The installation must be conducted according to the Rigitone Edge installation manual and the projects drawing material.

### Loading

Rigitone Edge = 3 kg/m<sup>2</sup>  
Grid system = 5 kg/m<sup>2</sup>

If higher loading is needed the installations are to be fixed to the slab above with dedicated suspensions.

### Fire resistance

A2-s1, d0.

### Stability

Rigitone Edge system is to be installed and used in rooms with relative humidity not exceeding permanently 70% or temperatures exceeding 45 degrees celcius.

### Cleaning

Can be cleaned with a damp cloth depending on the final surface treatment. Do not use detergents.

### Maintenance

Damages on edges or surfaces can be repaired by filling and painting.

### Building site / Before installation

It is advisable to contact the local Gyproc consultant for guidance before commencing the installation of the Rigitone Edge ceiling system.

### Rigitone Edge on GK system in two levels

**Installation of metal framing GK system and Rigitone® Edge ceiling boards.**  
**Prior to installation it is recommended to read the manual thoroughly.**

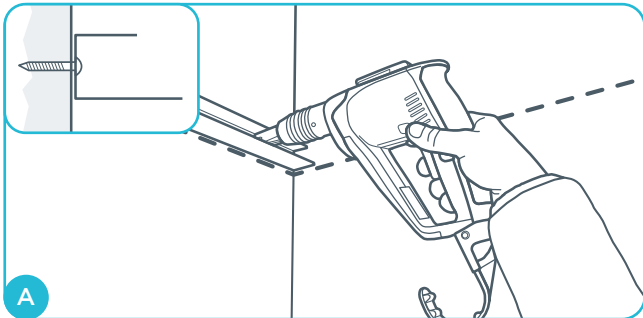

GK-C edge profile is attached to the walls according to the desired suspension height of the ceiling construction. Fix the GK-C edge profile to adjacent walls with appropriate fixing not exceeding cc distance of 400 mm. Carefully use the general specification material of the project as well as this installation manual.

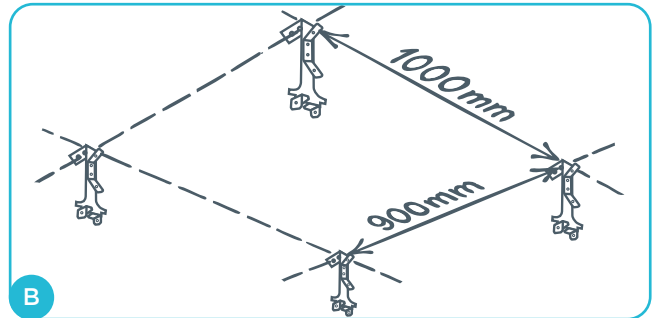

Conduct a survey of the room. Carefully plan for positioning of metal framing, ceiling boards and a potential perimeter frieze solution. Mark and fix suspension straps with appropriate fixings. Use 2 pcs of clips in connecting GK 27 and GK 26-27. Main profiles GK 1 at maximum 1000 mm apart and hangers maximum 900 mm apart.

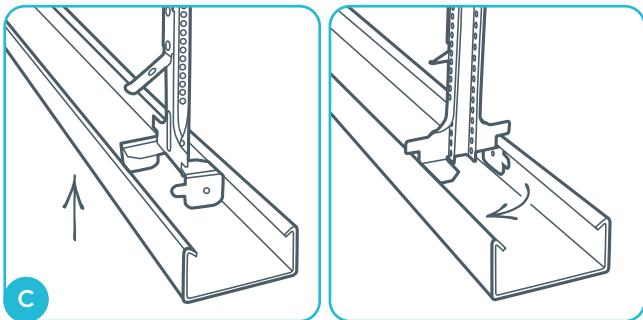

Lift the main profiles GK1 (cc max 1000 mm) up and attach the GK26-27 hanger to it, by twisting the hanger into the main profile.

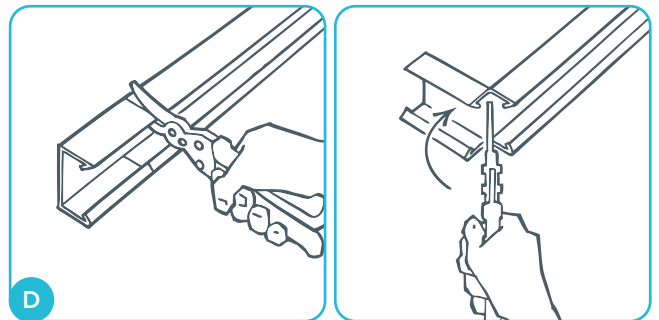

The GK1 main profile needs to be cut, so it has a distance of 3 mm from the walls. The GK1 main profile is placed on top of the GK-C perimeter channel.

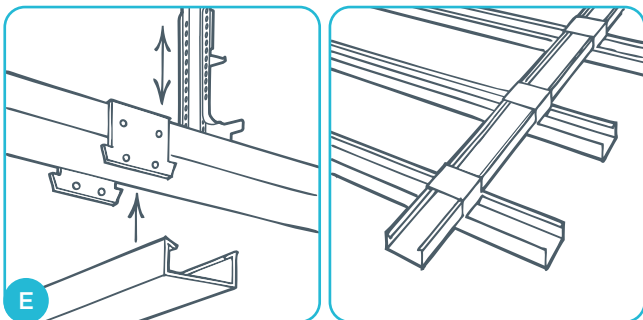

Place the jointing plate GK 22 on top of the main profiles. Then push the cross profiles (GK 1) up into the jointing plate. The cross profiles are pushed into the GK-C edge profiles. Cross profiles are installed with a distance of maximum 320 mm apart. But it is important that all the short edges on the Rigitone boards are fully supported by the cross profiles. See detail drawings on page 5.

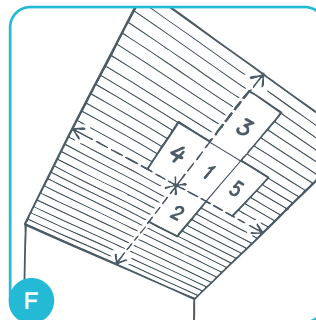

Install the first board in the middle of the room securing the width of the board along the cross profile. Use an alignment line, laser or preferably a fixed edge guide to ensure the board is properly aligned before screwing it into place. The short edge of the board is aligned in the middle of the width of the cross profile, leaving

space for the wide edge of the next board plus 3 to 4 mm clearance. The board widths are therefore parallel to the lines of the cross profiles to which they are secured whereas the board lengths are parallel to the lines of the main profiles. The rest of the boards are installed in a star pattern, working outwards from the center of the room.

### Installation of metal framing GK system and Rigitone Edge ceiling boards. Prior to installation it is recommended to read the manual thoroughly.

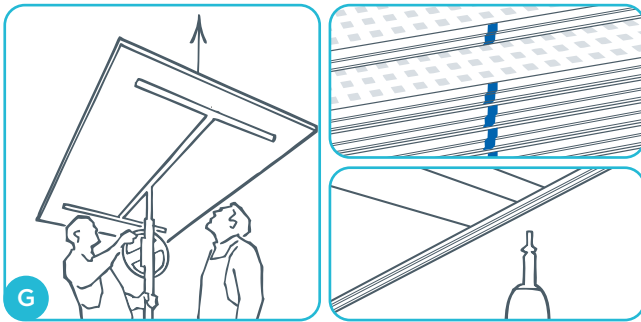

Install the Rigitone boards by using appropriate lifting equipment and fix to metal framing with QSTR25 screw. The maximum distance between the screws are 170 mm. Use the blue reference mark on one of the short edges of the board to decide on the direction of installation: All blue marks must face the same direction. Keep the boards firmly pressed to the overhead metal framing when screw fixing.

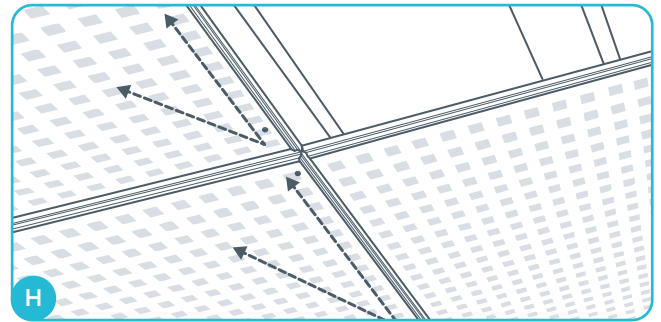

Position subsequent boards so that the perforations are aligned in the same diagonal direction seen from the length and the diagonal of the board. Boards are pushed close together). The Rigitone boards are sanded and primed from the factory, so no preparation of the boards is needed before installation.

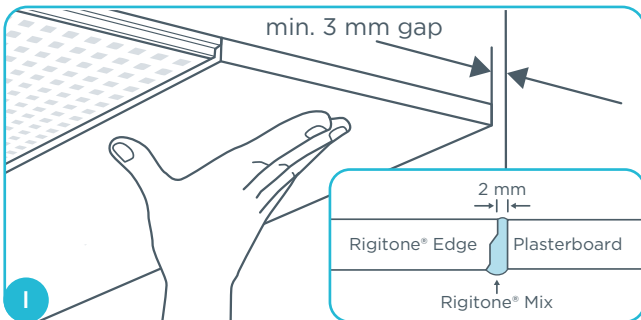

To compensate for tolerances in the main structure, it is a possibility to install non-perforated plasterboards, with a cut straight edge as a frieze solution. Note: all perimeter boards must keep a distance of 3mm from the walls. The perimeter boards also needs a distance of 2mm from edge of the Rigitone Edge boards. See page 6 for different solutions between ceiling and wall.

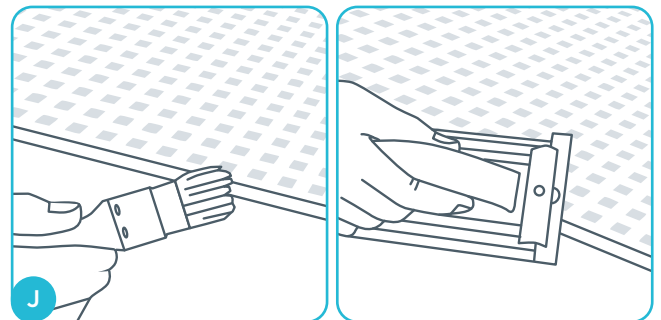

As the non-perforated plasterboard sheets with cut edges in a frieze solution or other cut edges on gypsum boards, are not prepped for installation. It is important that these cut edges are made ready for installation by sanding the cardboard using sandpaper and prime the cut edges of the boards using Rigitone primer. Sanding and priming is required on all cut edges.

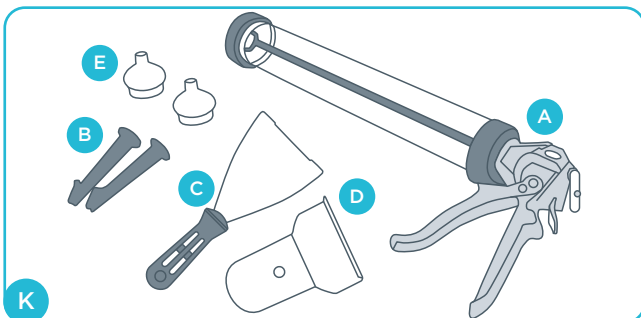

After installation of Rigitone boards and frieze boards. The joints are treated using the Rigitone Ready Mix filler. Rigitone Ready Mix Kit is used in applying the filler to the ceiling. The Kit consist of **A.** Filler gun, **B.** Filler nozzles, **C.** Filler scraper, **D.** Tool for filling screw holes, **E.** Filler nozzles adapters.

### Finishing

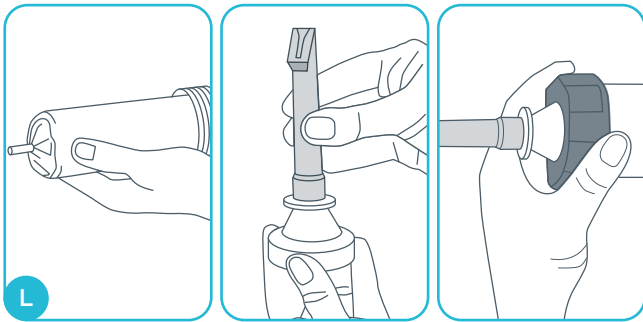

Take a bag of ready-to-use Rigitone 600ml Ready Mix, insert the bag containing the Rigitone Ready Mix into the filler gun and cut off the seal. Screw the Rigitone filler nozzle onto the adapter. Screw the Rigitone filler nozzle and attached adapter tightly onto the Rigitone Ready Mix filler gun, squeeze the trigger to force the filler out of the nozzle.

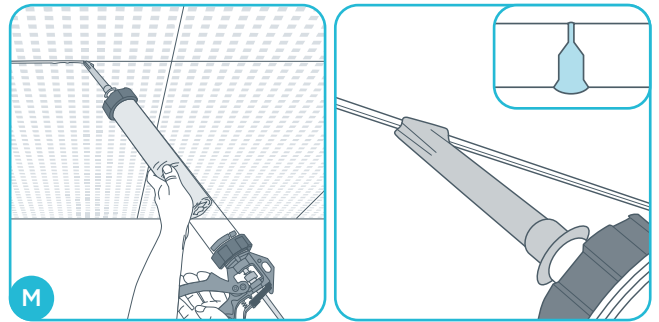

Fill the joints generously and completely with the Ready Mix filler, so that the filler just starts to exude from the backside of the board.

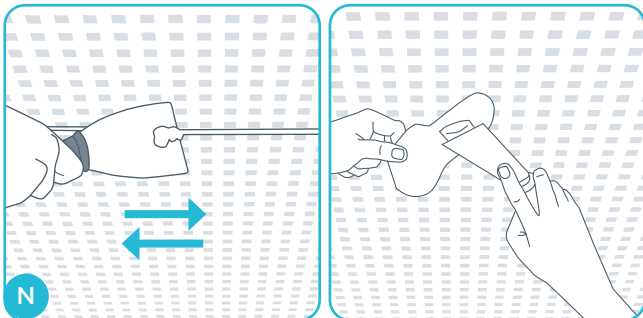

Slightly overfill the screw heads with Ready Mix filler or regular filler for plaster boards, using the Rigitone screw head template to protect perforation. Once the Rigitone Mix has begun to harden or after about an hour, remove any excess filler carefully using the Rigitone scraper and then pass the scraper back over the joints in the other direction to smooth the surface.

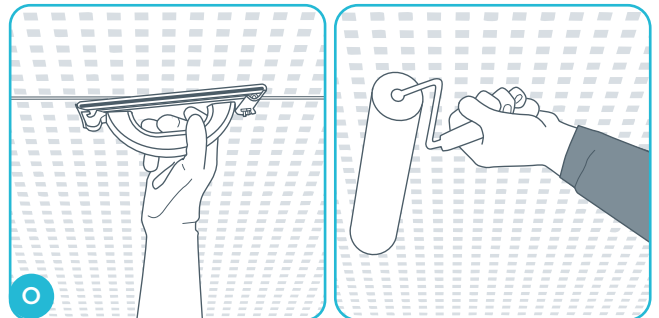

The joints and covered screw heads can be sanded after at least 24 hours. Further finishing work may be continued once the Rigitone Mix has fully dried. Painting of Rigitone are to be done with a short haired mohair roller to avoid excessive paint into the perforation. Spray painting are not to be used as paint will impair the acoustic tissue thus degrading the acoustic properties. After the Rigitone boards have been primed, they need at least 2 layer of painting.

### Expansion joints

Expansion joints for each 10 x 10 meters.

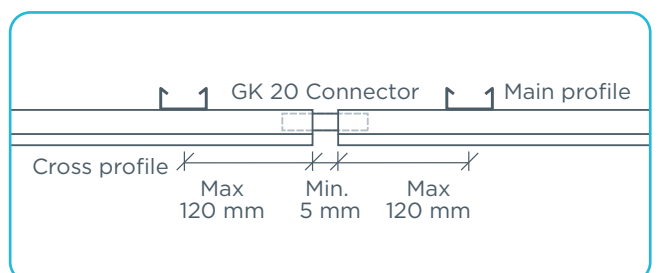
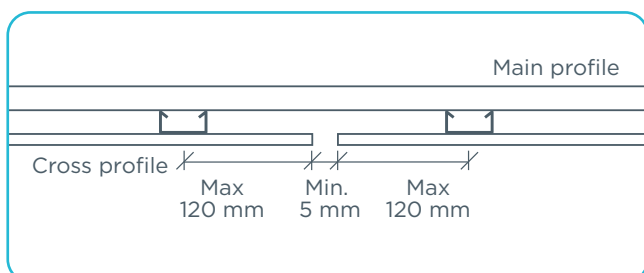

Rigitone boards must not have contact in the expansion joints. Main profiles may be continuous and cross profiles may not be continuous. But it can advantageously to inserted a GK20 assembly bracket in the expansion joint.

### Rigitone Edge - GK-system in 2 levels

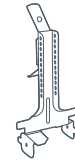
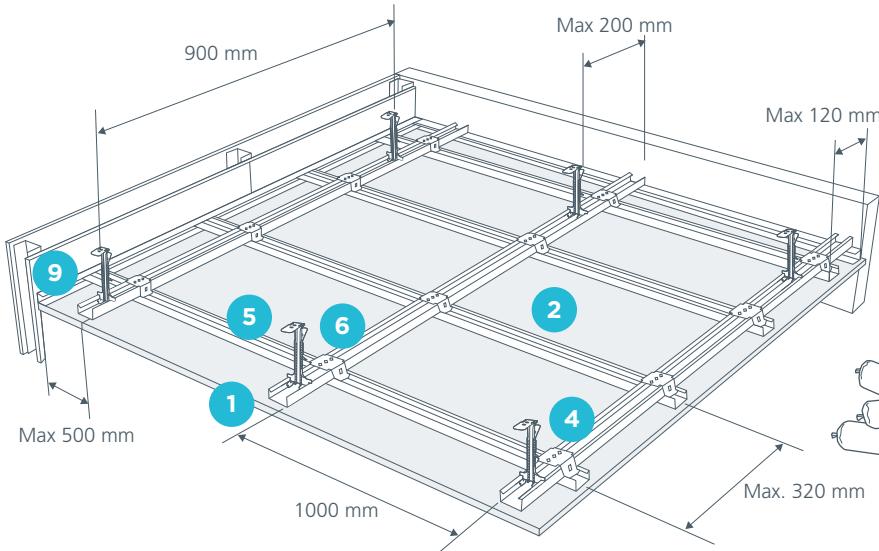

- 5 Suspension Strap GK 26-27** - Base including 2 pcs. clips



- 6 Suspension Strap GK 27** - top  
Length: 150/190/290/490/990 mm



- 7 Rigitone Ready Mix**  
600 ml bag for filler gun.

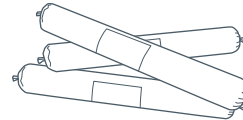

- 8 Type QSTR 25**  
Installation of Rigitone on metal framing.

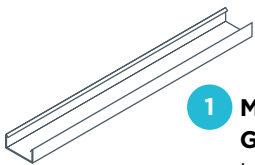

- 1 Main profile GK 1**  
L: 4000 mm



- 3 Connector GK 20**



- 2 Cross profile GK 1**  
L: 4000 mm



- 4 Jointing plate GK 22**

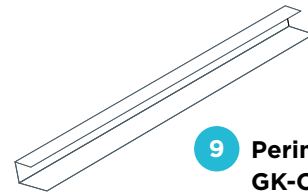

- 9 Perimeter channel GK-C**  
L: 3000 mm

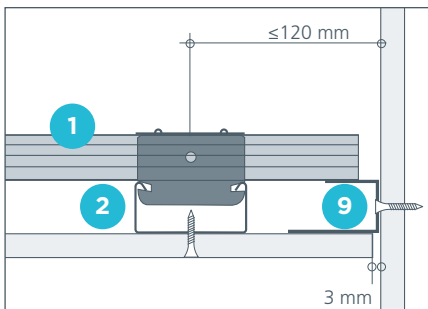

**Cross-section**

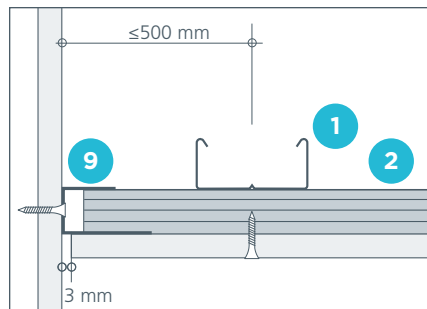

**Longitudinal-section**

**Note:**

The boards / metal framing must be kept from adjacent walls and therefore, is not to be attach to the wall. Do not screw attach the boards up into the GK-C perimeter channel.

### Estimated consumption, suspended installation of GK system in 2 levels

	Article	Designation	Dim. mm	Length mm	cc mm	Consumption/m <sup>2</sup>
1	Main profile	GK 1	27 x 60	4000	1000	1.0 m
2	Cross profile	GK 1	27 x 60	4000	Max. 320	3.6 m
3	Connector	GK 20	-	-	4000	1.0 pcs.
4	Jointing plate	GK 22	-	-	320	3.2 pcs.
5	Suspension strap	GK 26-27	-	-	900	1.1 pcs.
6	Suspension strap	GK 27	-	-	900	1.1 pcs.
7	Filler	Ready Mix	-	-	-	600 ml = Approx. 9 m <sup>2</sup>
8	Screw	QSTR 25	-	-	-	24 pcs.

**Guiding center distance on metal framing for mounting Rigitone products. Always do the measurement based on current board sizes** (max cc distance between cross profiles is 320 mm).

8/18	12-20/66	8-15-20	8-15-20 Super	8/18Q	12/25Q
cc 284 mm	cc 283 mm	cc 286 mm	cc 280 mm	cc 285 mm	cc 286 mm

### Edge closure with acrylic joint, with and without the use of GK-C perimeter Channel

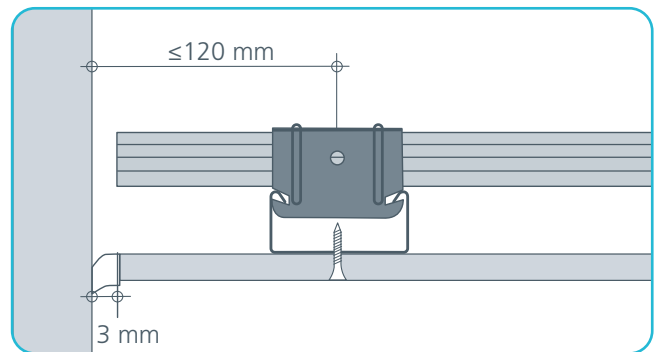
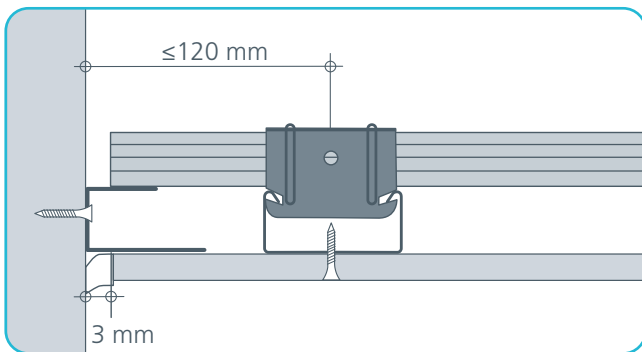

### Edge closure with edge Bead with and without the use of GK-C perimeter Channel

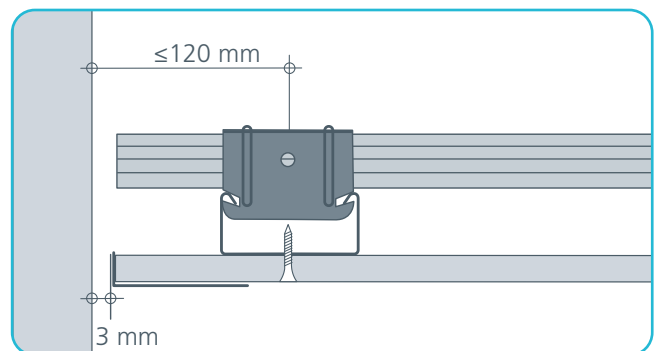
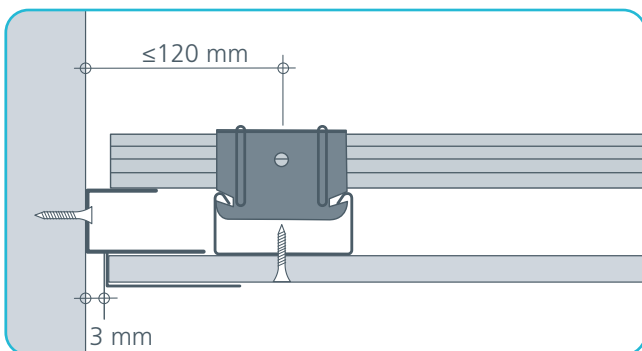

### Good advice when installing Rigitone Edge

#### The right use of grid

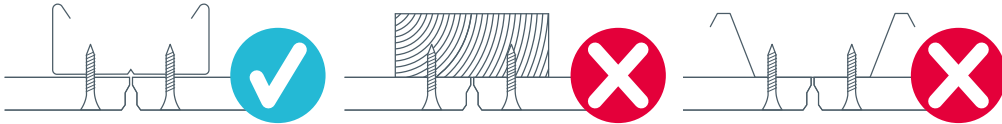

#### A 100% smooth base



#### Full contact between board and grid

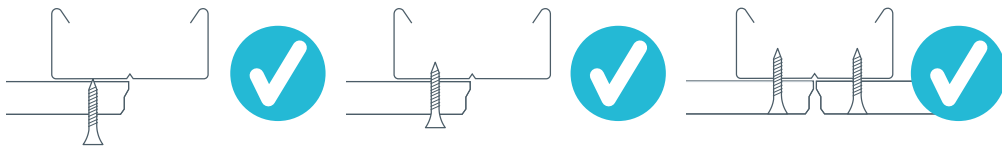

#### Avoid dust from screws on the back of the board

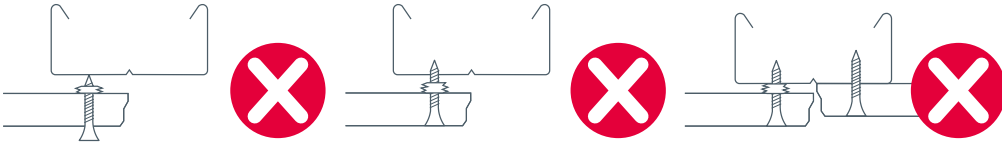

#### Rigitone boards are to be lifted vertically of the stack

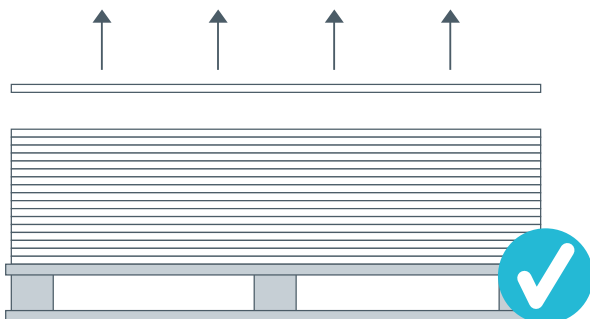

**NB:** By sliding the board, risk of rolling of tissue occur which will result in levelling problems at installation.

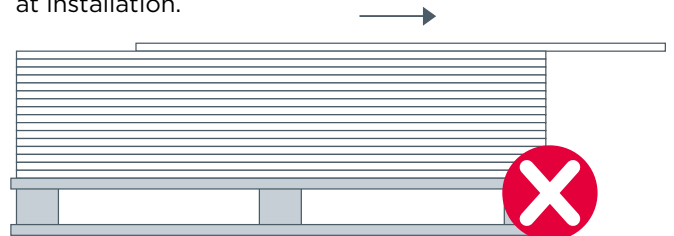

### Check list for installing Rigitone on GK system in 2 levels Prior to installation it is recommended to read the manual throughly.

- Humidity in room not to exceed 70% during installation or usage.
- Expansion joints must be made at. max 10 x 10 meters.
- Only use GK System in 2 levels when installing Rigitone.
- Make a thorough measurement of the room, before installation.
- The GK-C perimeter channel is used as support for the metal framing. But metal framing and Rigitone boards must not be attached to the GK-C perimeter channel with screws.
- Survey the room and position the straps according to this manual and the general specification of the project.
- Installation of straps. Always use fixed adjustable straps GK 26-27 / GK 27 for installation of main profile GK 1.
- Suspension of main profiles GK1. Main profile at max cc 1000 mm.
- Mounting and fastening cross profile GK1. Cross profile at max 320 mm. Distance can however vary by board size. First cross profile is placed max. 120 mm from adjacent wall.
- The metal framing is adjusted to horizontal. Metal framing might need to be secured with cross stiffening.
- Cross-mounting must always be carried out with the Rigitone boards.
- All short edge assemblies must be fully supported by cross profiles
- Always start the assembly of the Rigitone ceiling from the center of the room. Note that the board size varies depending on the type of perforation.
- Always check that the back of the board is clean and not filled with debris from the acoustic tissue.
- When using smooth plaster-board as a frieze, the edge towards the Rigitone Edge, always needs to be a right cut, straight edge.
- Only use Ready Mix as a filler For the joints between the Rigitone boards.
- All cut edges both on Rigitone and smooth plasterboards must be sanded and primed before installation.
- Note that metal framing, Rigitone ceiling and frieze plates must be kept free from adjacent walls.



**SAINT-GOBAIN**

**Placoplatre SA**

Tour Saint-Gobain  
12, place de l'Iris  
92400, Courbevoie  
France  
Tel.: +33 1 88 54 00 00

[www.placo.fr](http://www.placo.fr)